

T1-PCM-BATT

Digital Telemetry System for Strain Gage Applications on Rotating Shafts Operating Instructions



- Easy to assemble and operate
- Strain gage sensors (>350 Ohm)
- Full- and half bridge configuration
- Excitation fixed 4 Volt DC
- Auto-Zero adjustment
- Gain: 250-500-1000-2000 or 1000-2000-4000-8000
- 16 bit ADC
- Digital transmission realized inductively
- Distance up to 150mm (Range)
- Powering of transmitter part via battery 6-9V
- No influence through radio frequency
- Many systems can operated at the same time
- Signal bandwidth 0...1200Hz (-3dB)
- Output +/-10V
- Output 4-20mA (Option)
- System accuracy <0.2%

General description

The T1-PCM-BATT single-channel telemetry system offers the easiest handling for the wireless transmission of strain gage signals from rotating shafts. The encoder 35x24x14mm with a weight of 16g. The transmitter (encoder) part is simply mounted on the rotating shaft with a special fiber reinforced tape.

The data transfer between transmitter and receiver is digital. The powering of the transmission part by the T1-PCM BATT is supplied by 6-9V battery.

Functional description

The T1-PCM-BATT transmitter provides a pulse code modulated signal (PCM) to an induction winding around the shaft. The magnetic field of this winding enables the inductive transmission of the signal from coil to pickup. From there the signal is transferred by cable (5 m) to the receiver. The maximum distance between the transmitter coil and the pickup is 150mm.

The receiver unit offers a BNC connector at the front panel with analog outputs ± 10 V and optional a current output of 4-20mA

Strain gage sensors (>350 Ohm) in full- and half- bridge configuration can be directly connected to the transmitter. The excitation is fixed to 4 Volt DC and the gain is set by plug-In bridge in 4 steps (250-500-1000-2000 or 1000-2000-4000-8000). An auto-zero (AZ) adjustment is executed by pressing the AZ button on the front side of the receiver. The successful AZ operation is indicated by a yellow LED. The yellow LED flashes as long as the AZ is in progress. When the AZ completes the LED continuously illuminates. The AZ setting is stored in a Flash-RAM and thus is not lost during power-off. Use only shielded sensor cable.

T1-PCM- set contains:

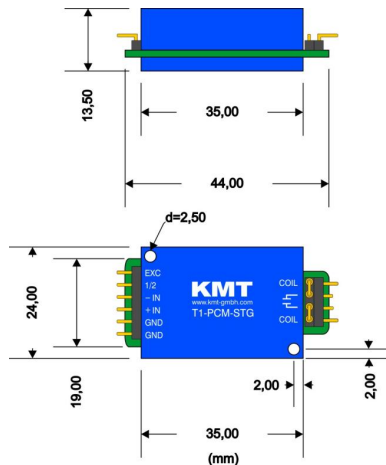
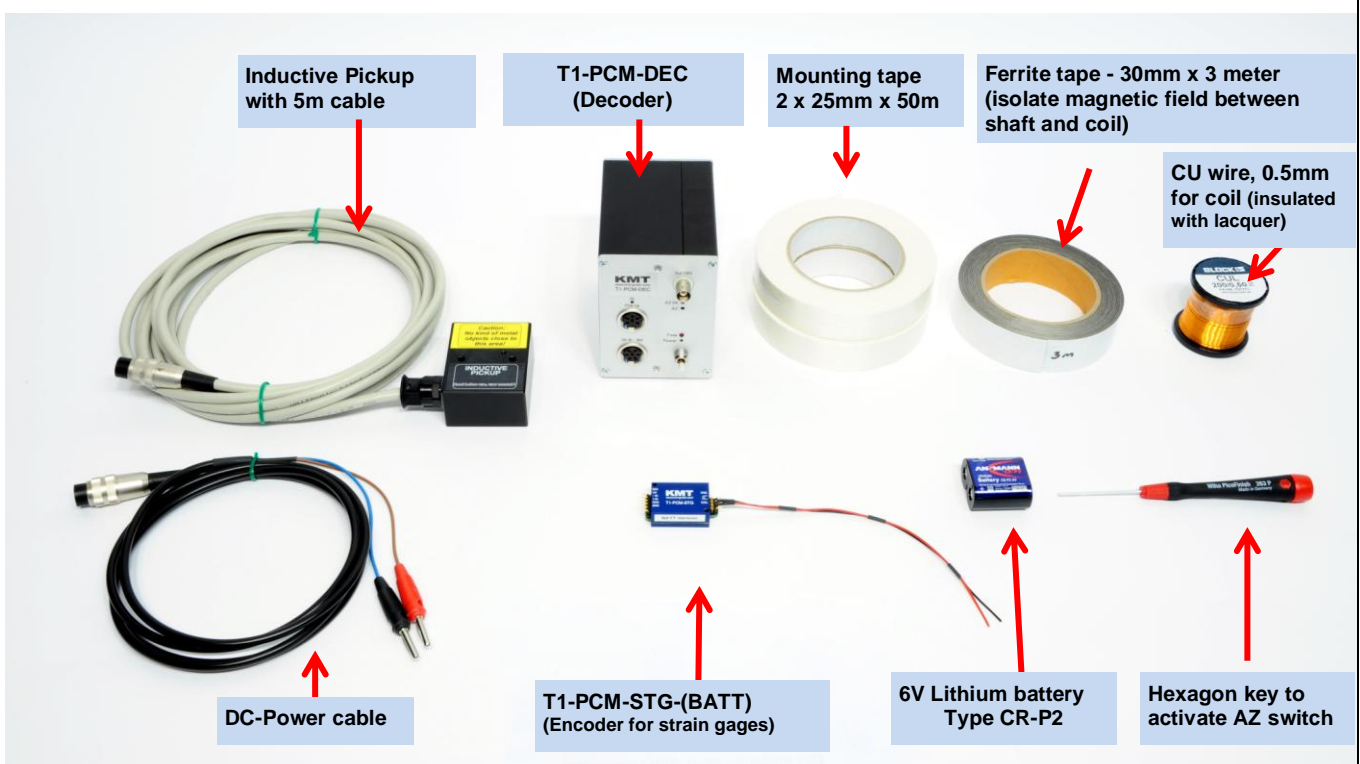

Technical data transmitting part:

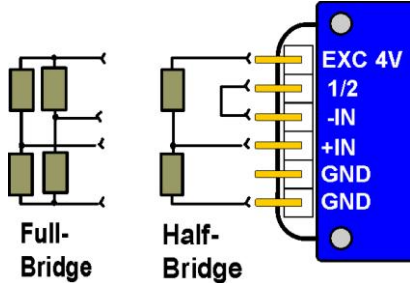

T1-PCM-STG

Strain gage: Full and half bridge >350 Ohm,
Excitation: 4 VDC (fixed)
Gain: 250-500-1000-2000 standard
1000-2000-4000-8000 **On request**

Gain and Sensitivity

Gain 250 = +/-10mV/V	Gain 2000 = +/-1.250mV/V
Gain 500 = +/-5mV/V	Gain 4000 = +/-0.625mV/V
Gain 1000 = +/-2.5mV/V	Gain 8000 = +/-0.3125mV/V

AZ: Auto Zero calibration (via AZ button from receiver side)
Analog signal bandwidth: 0 - 1200 Hz (-3 dB)
Operating temperature: - 10 to + 80 °C
Resolution 16bit
Scanning rate 7.5kHz
Static acceleration: up to 3000g
Powering: Battery 6-9V, current consumption 80-100mA
Dimensions: 35x24x14mm, weight 16g
Housing: splash-water resistant IP65 (except the connector pins)



T1-PCM-Pt100

Pt100 thermo sensor
Measurement range -50 to 250°C or -50 to 500°C (select by jumper)
Analog signal bandwidth: 0 - 10 Hz (-3 dB)
Operating temperature: - 10 to + 80 °C
Resolution 16bit
Scanning rate 7.5kHz
Static acceleration: up to 3000g
Powering: Battery 6-9V, current consumption 80-100mA
Dimensions: 35x24x14mm, weight 16g
Housing: splash-water resistant IP65 (except the connector pins)

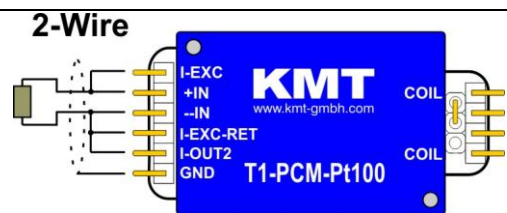
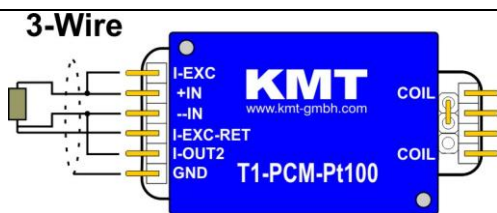
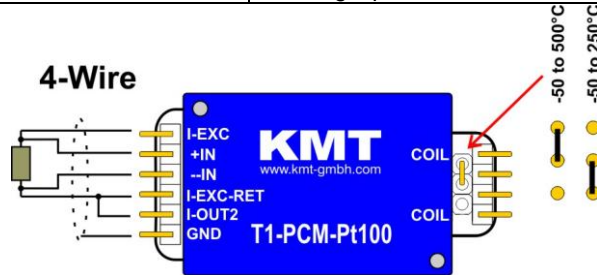

Dimensions Encoder - T1-PCM-STG

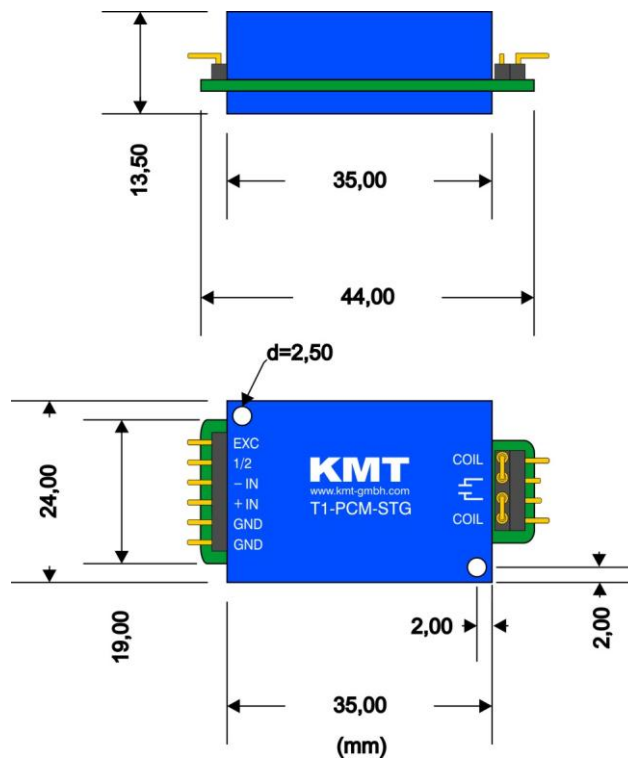

Draw about 1:1

Weight 16 gram

Technical data receiving part

 <p style="text-align: center;">Front Rear</p>	<p>T1-PCM-DEC <u>Front side:</u> Analogue output: +/-10V via BNC (Optional 4-20mA output) Auto Zero setting: via AZ button Autozero LED: Yellow ON- successful AZ Yellow OFF- not successful AZ <i>if flashing, call support of KMT, error in EPROM</i> SL LED: Red ON = if error of data transmitting SL LED: Red Flashing = distance to far Power ON LED: Red ON = if power switch on</p> <p><u>Rear side:</u> Output to Powerhead: via 6-pol. Tuchel Fuse LED: Flashing if fuse is defect Powering: 10-30V DC, Input via 7-pol. Tuchel Switch: ON/OFF Operating temperature: - 10 to +70 °C Dimensions: 75 x 105 x 105 (without connectors!) Weight 750 grams Static acceleration: up to 200g System accuracy*: +/- 0.2 % <i><*measure with gain 1000, 350ohm (0.1%) full bridge - test bridge!></i></p>
	<p>T1-PCM-Pickup (standard version) Function: Receiving inductive PCM modulated data from the coil of the <u>T1-PCM-STG unit</u> Distance between the transmitter coil and the pickup is 5-150*mm Output to T1-PCM-Decoder: Via 6-pol. Tuchel plug incl. 5m cable Operating temperature: - 10 to +80 °C Dimensions: 53x66x30mm (without cable) Weight: 200 grams (without cable!) Housing: splash-water resistant IP65 (except connector). Cable length standard 5m! Optional 10, 15, 20 or 25m</p> <p><i>*(depend of shaft diameter!)</i></p>

Block diagram

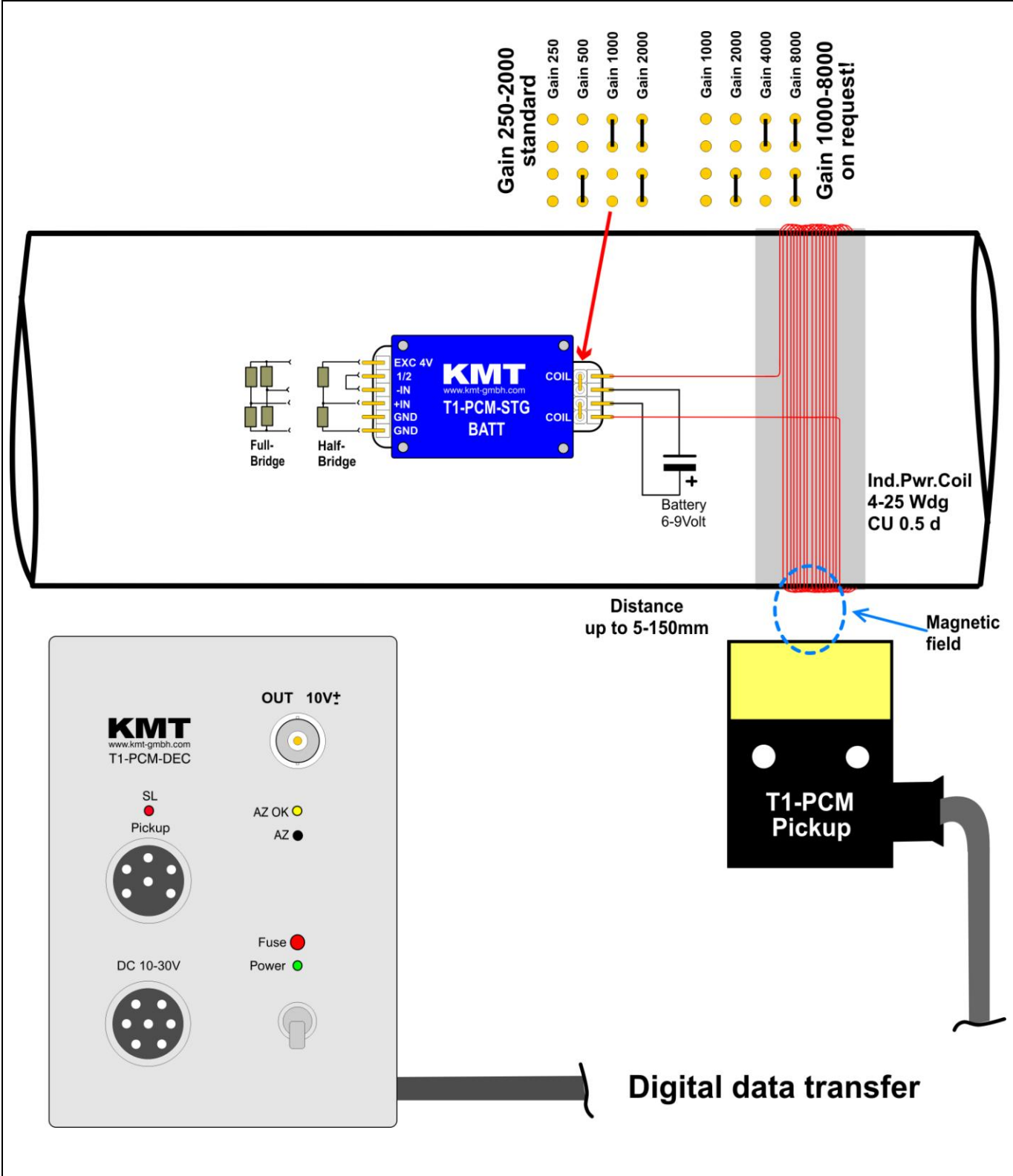

Note: The Pickup head must be fixed in the middle of the coil in a distance from 5 to 150 mm.

Receiving part:

Front

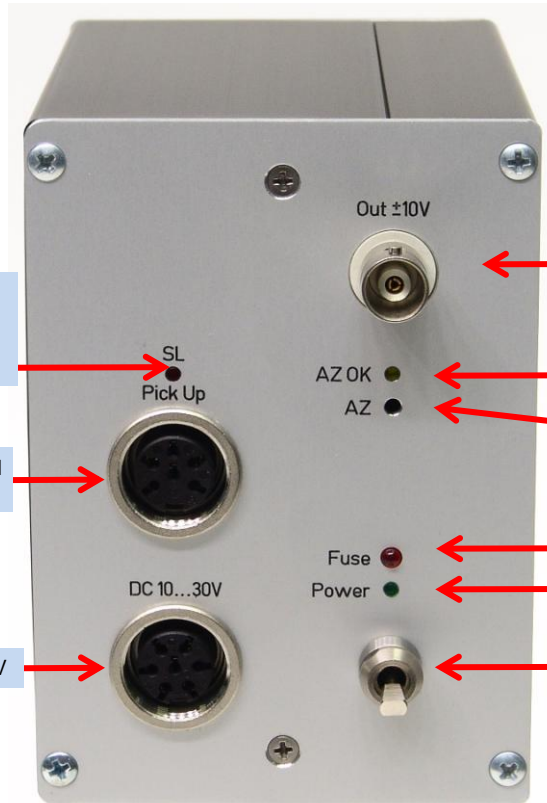

LED ON = Error data transmission
LED Flashing = Distance between Coil and Pickup is too far away

Data input from Pickup and output to Powerhead

Power IN DC 10 – 30V

Analog output +/-10V

Yellow ON- successful AZ
Yellow OFF- not successful AZ
If flashing, call support of KMT, error in EPROM

AZ button

Flashing if fuse damage

Power ON LED

Power ON/OFF switch

Rear

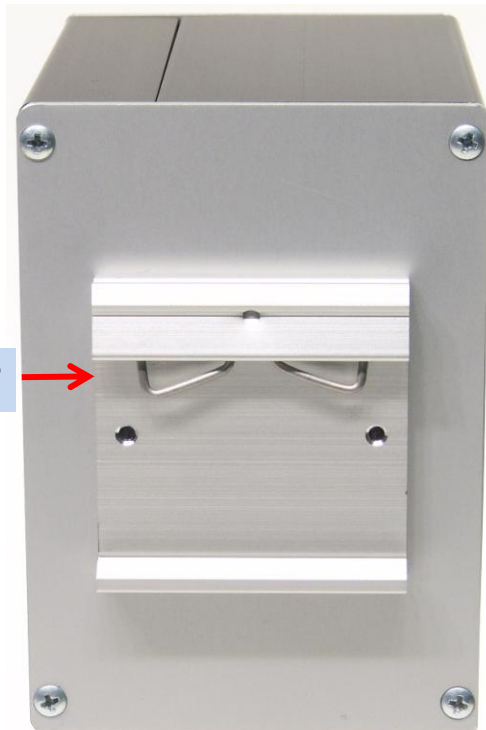

Top-hat rail mounting clip (Option!)

Pin connection cable:

Powerhead / Pickup

Standard version for distance of 5-30*mm
 *(depend of shaft diameter!)

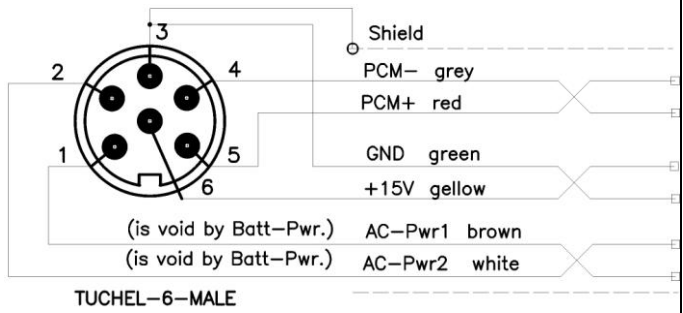

DC-Power cable

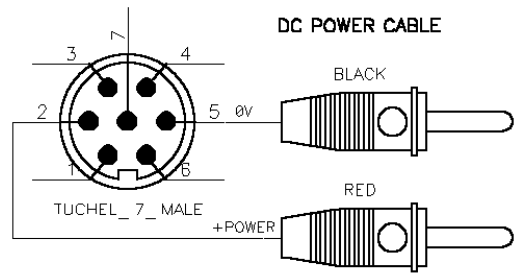

Shaft installation

2 layers (layer by layer) of the special ferrite tape around the shaft

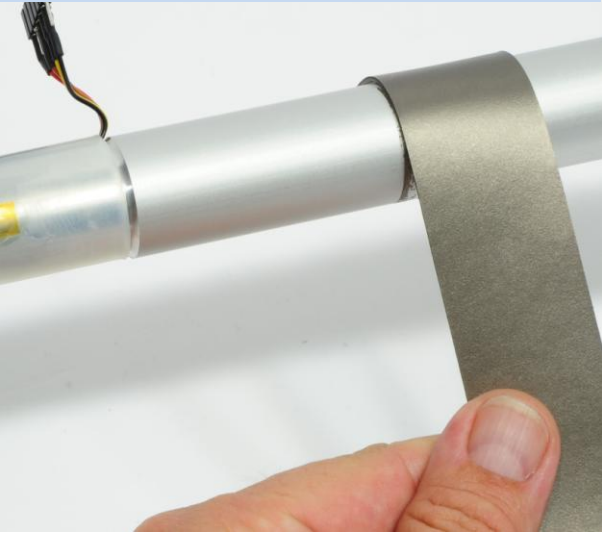

Fix with 2 layers of mounting tape around the shaft

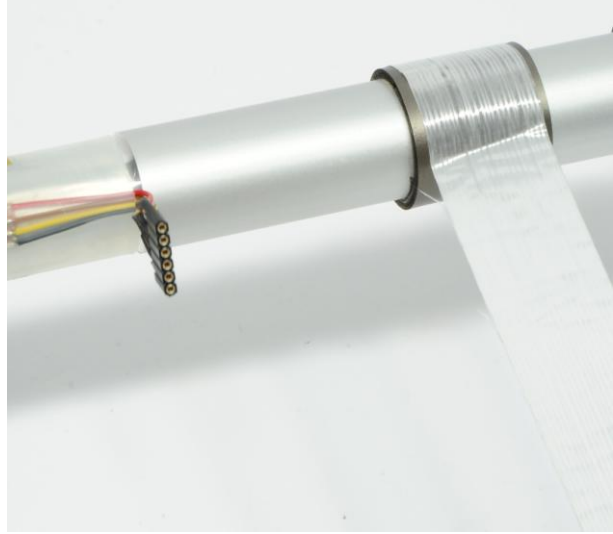

Coil, depends of shaft diameter 4-25 parallel windings of 0.5 CU wires, see table for help.

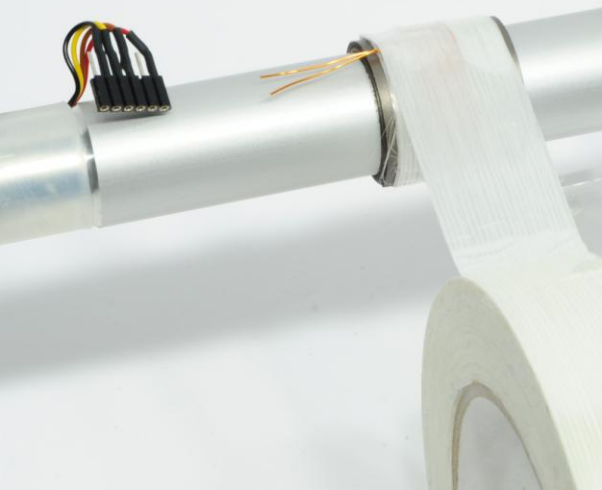

Fix with 2 layers of mounting tape around the coil



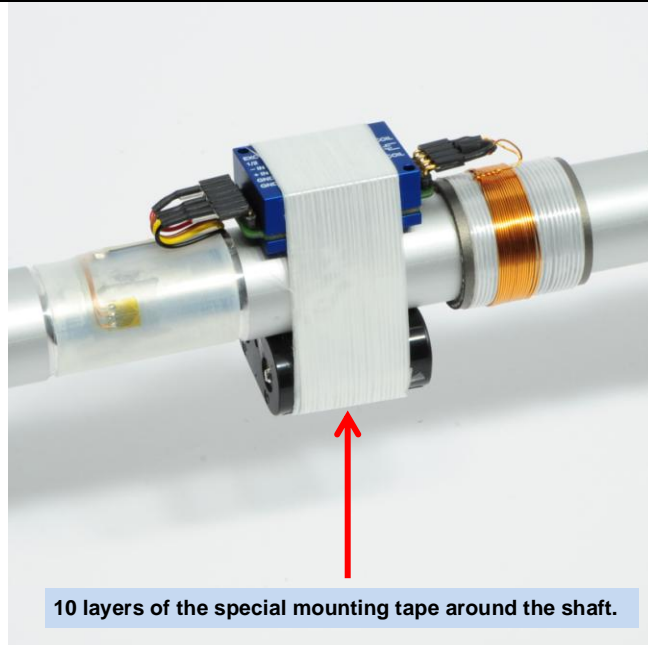
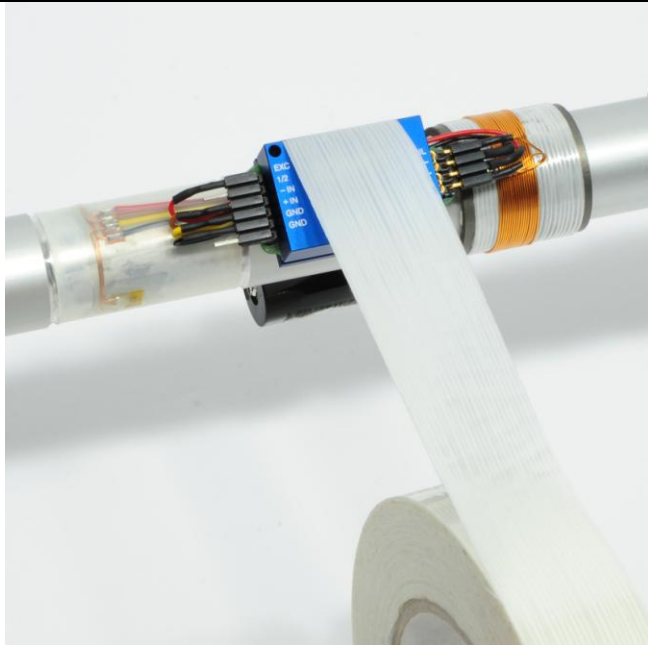

10 layers of the special mounting tape around the shaft.



We recommend add. use a steel hose clamps for final fixing!!

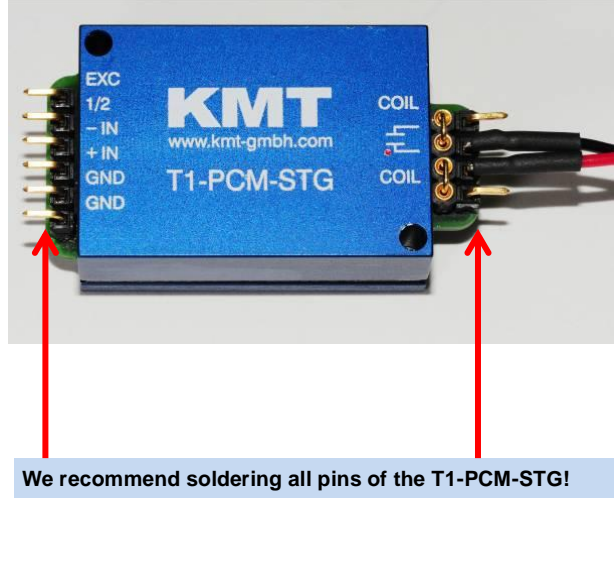

We recommend soldering all pins of the T1-PCM-STG!

Caution:

Fix T1-PCM-STG module with at least 10 layers of the special mounting tape around the shaft. Depending on the shafts RPM and diameter particular attention needs to be paid to the safe mounting of the components.

The manufacturer doesn't accept liability for damages, which results from insufficient attachment of the individual components.

The tape is only for test purposes, in order to test the electrical function of the units in the idle state of the shaft.

During the rotation test appropriate safety precautions should be taken.

The entire installation may be used only by authorized persons. By using tape for the attachment, it has to be used in the direction of rotation of the shaft and the end has to be secured. Only non-elastic tapes with high tensile strength should be used for pre-fixing. Additionally, use **hose clamps for final fixing!!** The individual components are to be distributed in such a way on the shaft that imbalances are avoided.

Find the correct amount of windings

The number of windings depends on several factors. The most important influential factors are the diameter, the material of the shaft and the environment around the shaft. The table standing below will help you to find the right number windings for steel shafts. The table below is a help to estimate the number of windings fast. To optimize your results you can try one winding more or less.



Coil, depends of shaft diameter 4-25 windings of 0.5 CU wire

Optimum windings of steel shafts for inductive data transmission

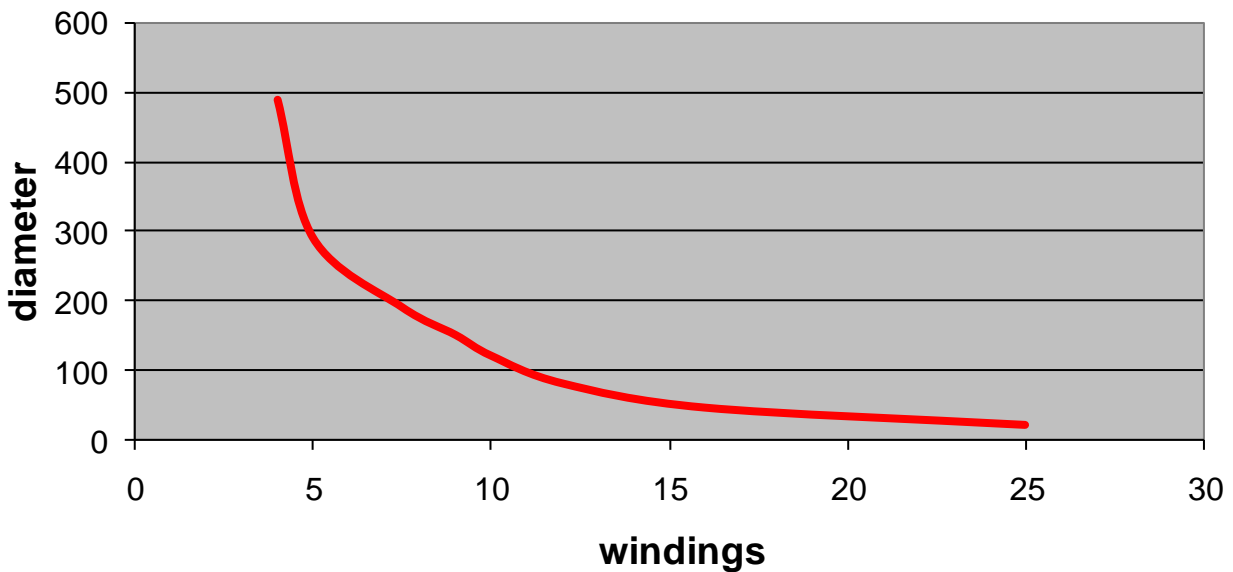

Diameter (mm)	Windings
490	4
290	5
190	7
150	9
120	10
80	12
45	16
20	25

Dimensions Powerhead / Pickup

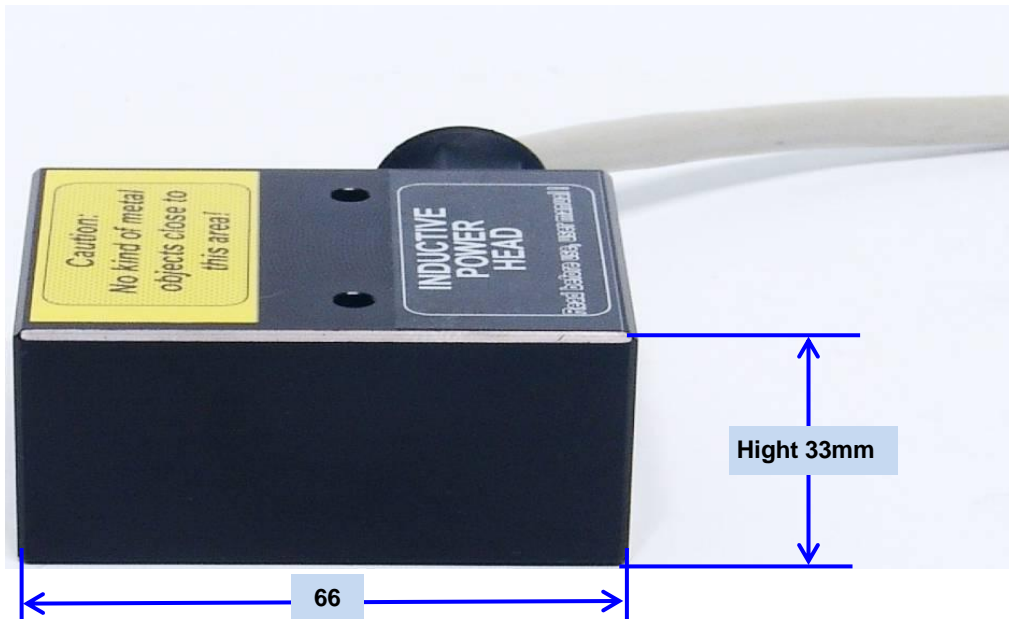
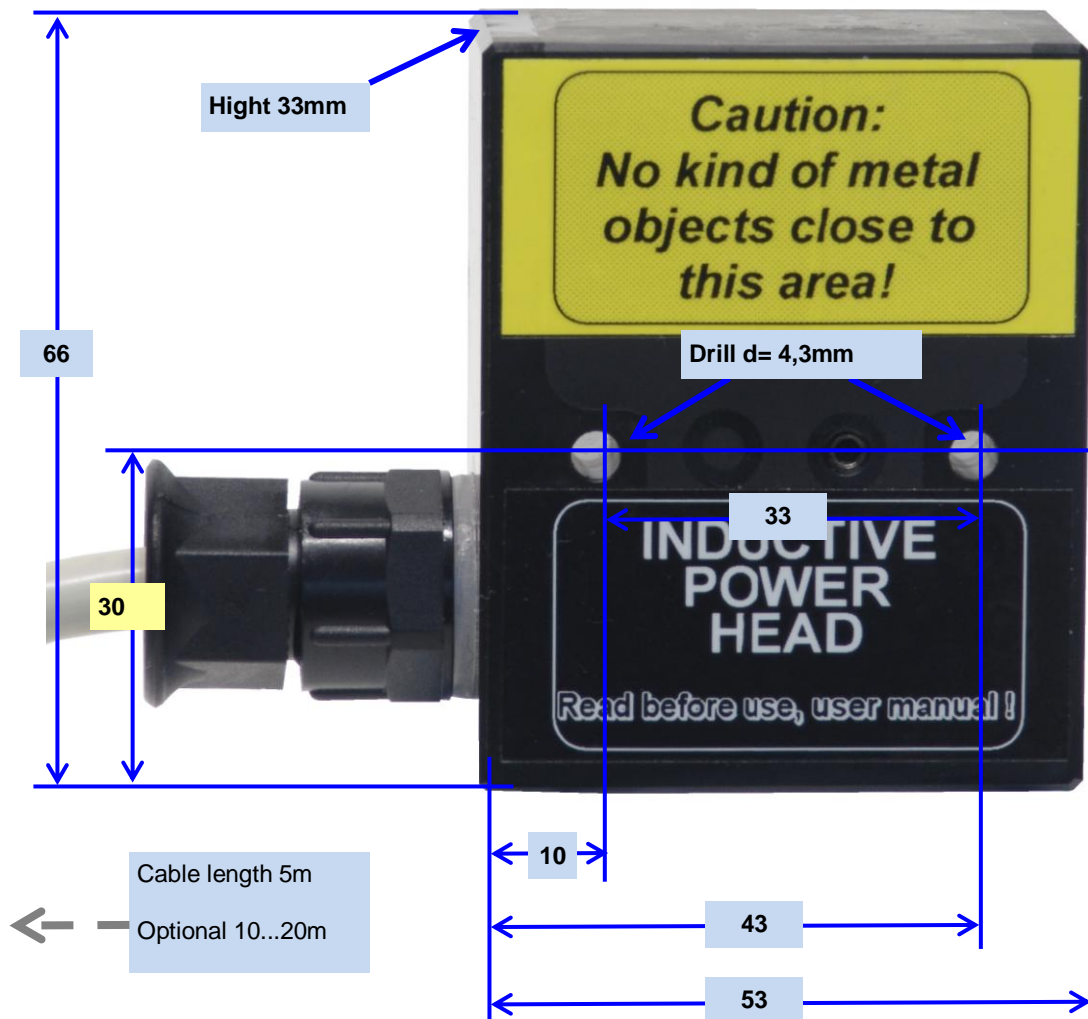

Attention

- Use only shielded sensor cable
- When used on rotating shafts, all connections must be soldered.
- Mounting of the modules on a shaft must be first fixed with mounting tape (only for prefixing) and then with a hose clamps!!!





Konformitätserklärung

Declaration of Conformity
Déclaration de Conformité

Wir
We
Nous

KMT - Kraus Messtechnik GmbH

Anschrift
Address
Adress

Gewerbering 9, D-83624 Otterfing, Germany

erklären in alleiniger Verantwortung, daß das Produkt
declare under our sole responsibility, that the product
déclarons sous notre seule responsabilité, que le produit

Bezeichnung
Name
Nom

Messdatenübertragungssystem

Typ, Modell, Artikel-Nr., Größe
Type, Model, Article No., Taille
Type, Modèle, Mo.d'Article, Taille

T1-PCM-IND, T1-PCM-BATT

mit den Anforderungen der Normen und Richtlinien
fulfills the requirements of the standard and regulations of the Directive
satisfait aux exigences des normes et directives

108/2004/EG

Elektromagnetische Verträglichkeit EMV / EMC

DIN EN 61000-6-3 Ausgabe 2002-8 Elektromagnetische
Verträglichkeit EMV Teil 6-3 Fachgrundnorm Störaussendung

DIN EN 61000-6-1 Ausgabe 2002-8 Elektromagnetische
Verträglichkeit EMV Teil 6-1 Fachgrundnorm Störfestigkeit

und den angezogenen Prüfberichten übereinstimmt und damit den Bestimmungen entspricht.
and the taken test reports and therefore corresponds to the regulations of the Directive
et les rapports d'essais notifiés et, ainsi, correspond aux règlement de la Directive.

Otterfing, 27.04.2008

Martin Kraus



Ort und Datum der Ausstellung
Place and Date of Issua
Lieu et date d'établissement

Name und Unterschrift des Befugten
Name and Signature of authorized person
Nom et signature de la personne autorisée