

# IND-PWR XXL

## User Manual

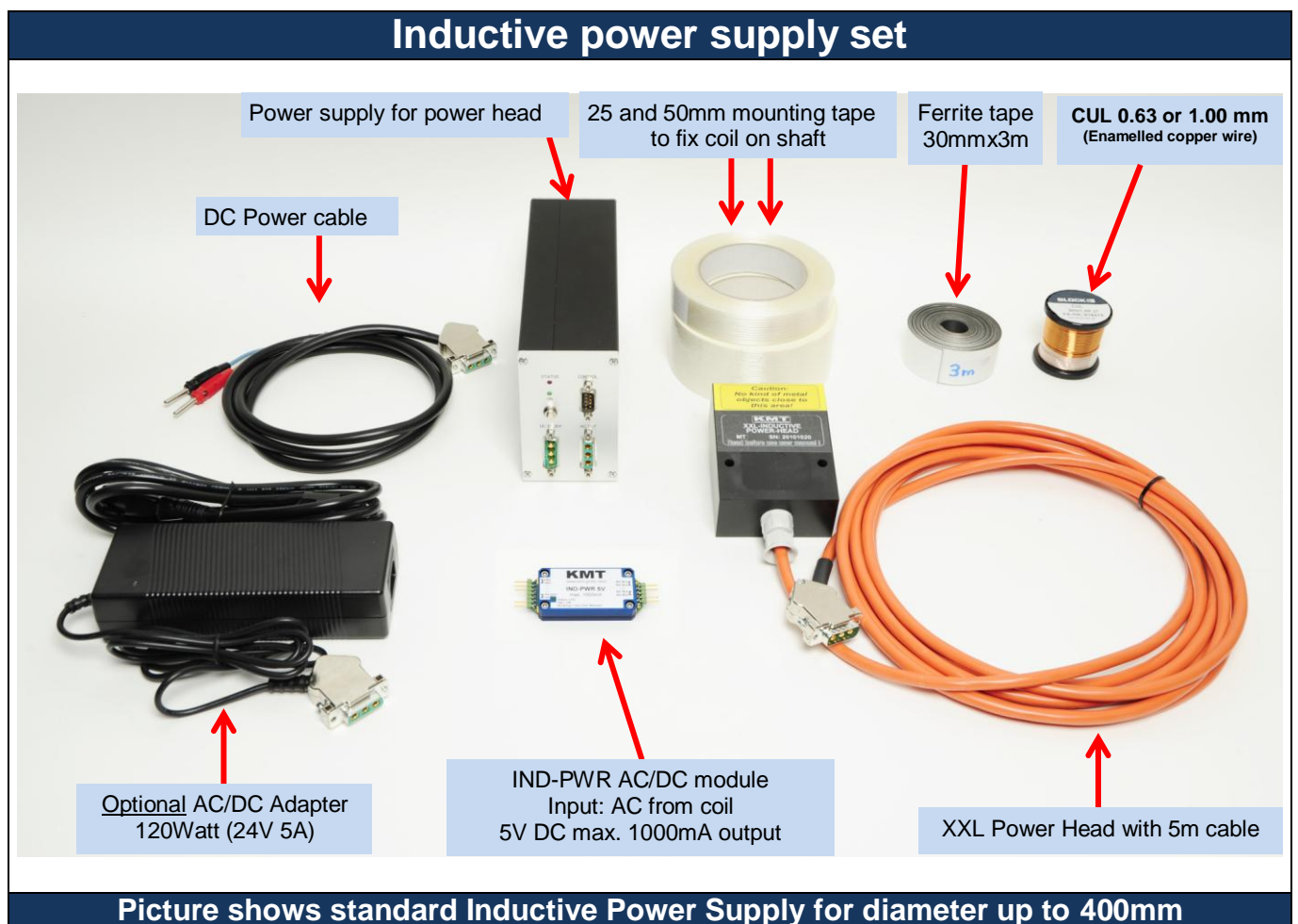

## MT32-IND-PWR 5V - AC/DC Module for inductive power



**MT32-IND-PWR 5V**  
 AC/DC Module for inductive power  
 Input: 30-60kHz, 10-50V AC  
 Output: 5 VDC  
 Current: up to 1000mA  
 Weight: 35 gram  
 Vibration: 5g  
 Shock: 3000g

### Pin assignment

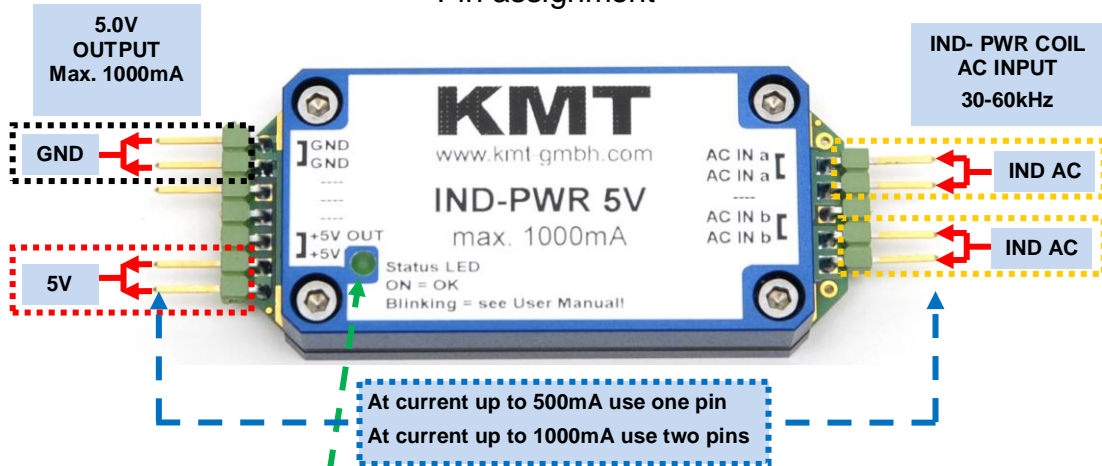

#### Status LED

LED ON = right windings and good distance between head and coil

LED very low blinking = too less windings of IND-Coil or too large distance between head and coil!

LED fast blinking = too much windings (OVER POWER at IND-Coil) reduce windings or module go hot and switch OFF

## MTP module housing - dimensions

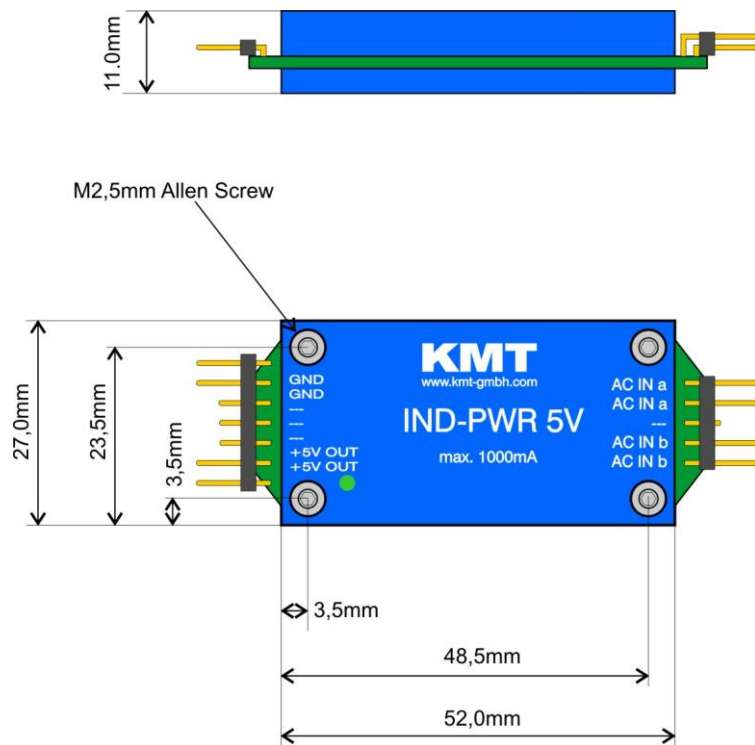

Weight about 35 grams

## Inductive power supply Installation of coil for inductive powering on shaft

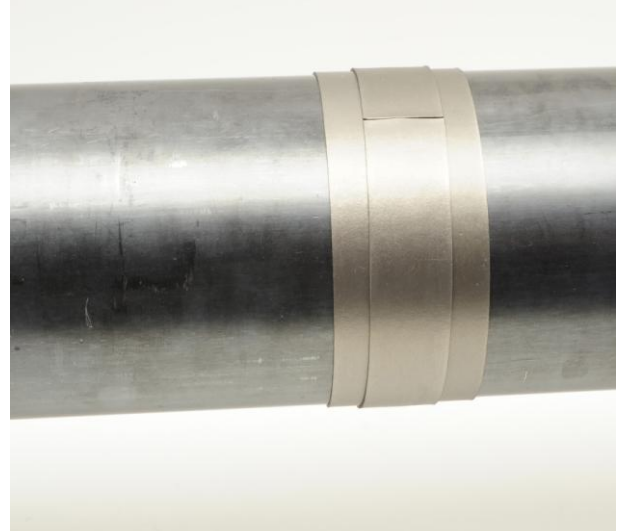
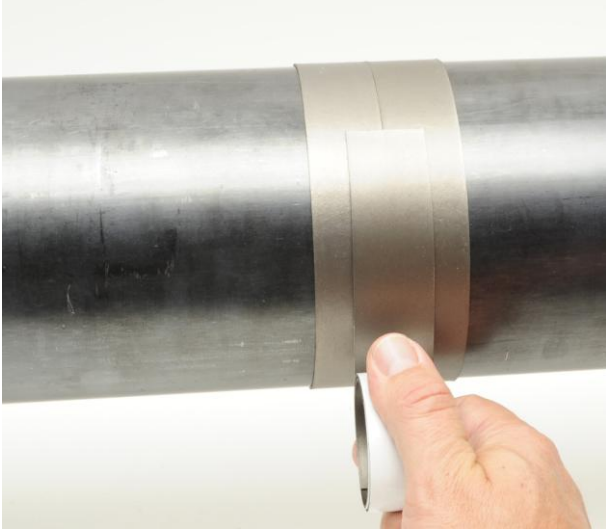
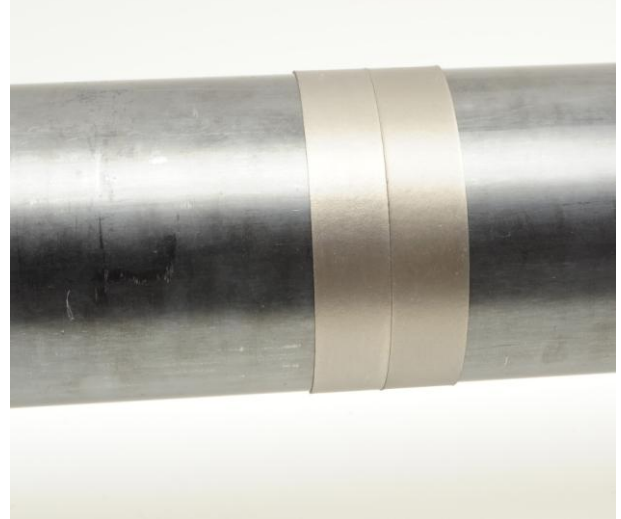

Attach for electromagnetic isolation "Ferrite Tape" 2x parallel and 1x in the middle over two layer around the shaft

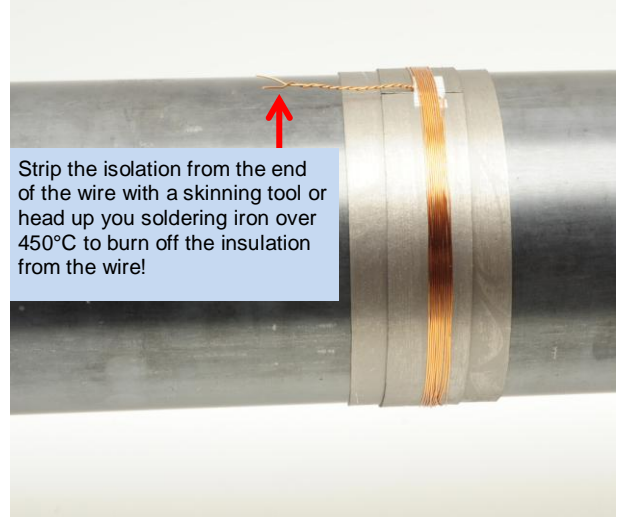
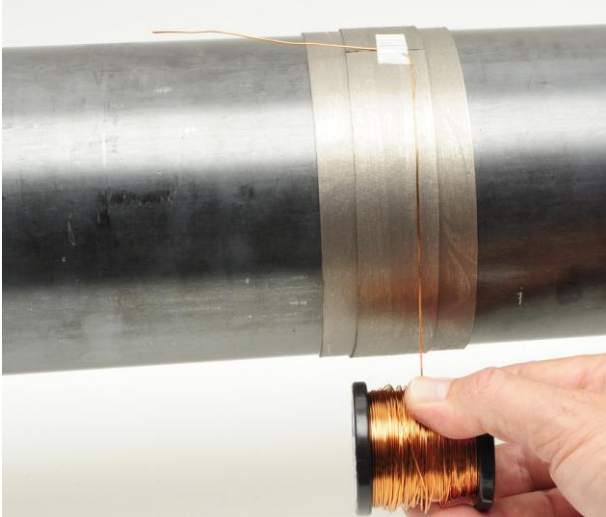

Strip the isolation from the end of the wire with a skinning tool or head up you soldering iron over 450°C to burn off the insulation from the wire!

Make power coil with 3-18 windings for 1000-20mm diameter (see diagram) and twisted the end of wire.  
Use 0.63...1.00 mm (1.00mm for diameter of 200-1000mm) CUL wire (Enamelled copper wire)

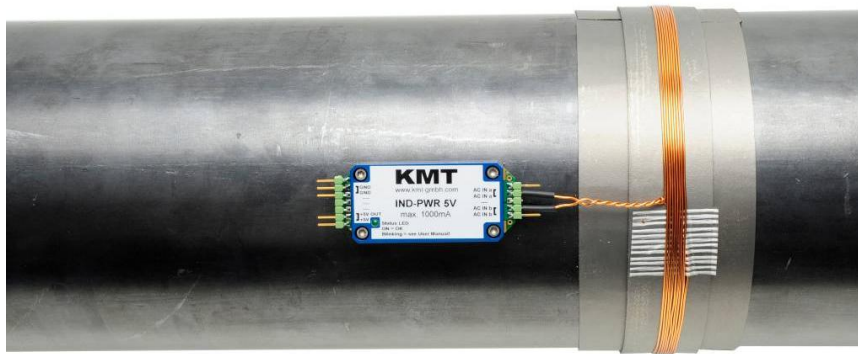

**Solder the end of the pins on the AC IN of the IND-PWR module and isolate all solder points with shrink tubing  
Fix all with 5 layers mounting tape!**

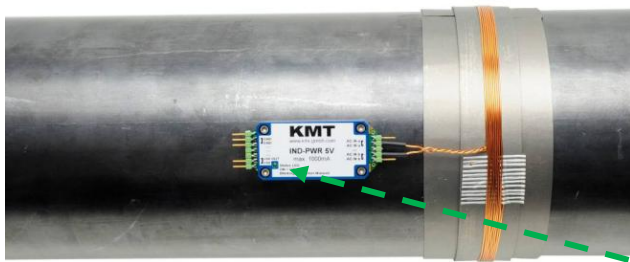

Note: "The inductive load of the MT32- IND-PWR and the capacitor in the Power Head must be in resonance to get the optimal transmission. The inductive load of the shaft depends of diameters, material and number of windings!

Control the output voltage and move the power-head in the max distance to the coil.  
The output voltage must be 5V

**See also status LED**

LED ON = right windings and good distance between head and coil

LED very low blinking = too less windings of IND-Coil or too large distance between head and coil!

LED fast blinking = too much windings (OVER POWER at IND-Coil) reduce windings or module go hot and switch OFF

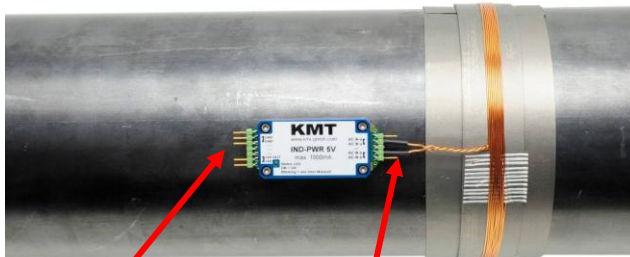

**5V DC OUT  
max. 1000mA**

**AC IN**



The pins "Coil" are the AC power input from the coil. On the pins "+5V and "GND" you get a stabilized output voltage of 5V DC.  
The max. load current on the DC output is max. 1000mA.

The IND-PWR converter will use instead battery pack!  
**Never use any battery together with the IndPwr!**

You should mount the power head at a fixed location that it's as free as possible from strong vibration influences.

The center of the coil should be in the same horizontal position as the center of the power head. The distance is optimal in the range between 5 and 10mm. (depends of shaft and current consumption)

## Find the correct amount of windings of inductive power coil

### Optimum windings for steel shafts

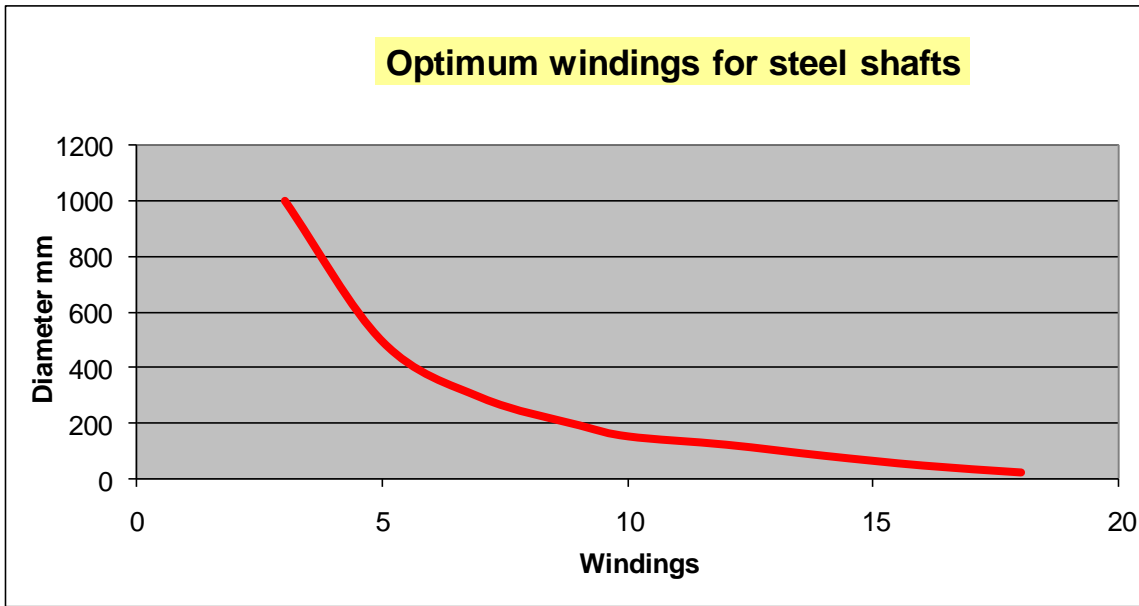

Diameter (mm)	Windings (+/-1)
1000	3
490	5
290	7
190	9
150	10
120	12
80	14
45	16
20	18

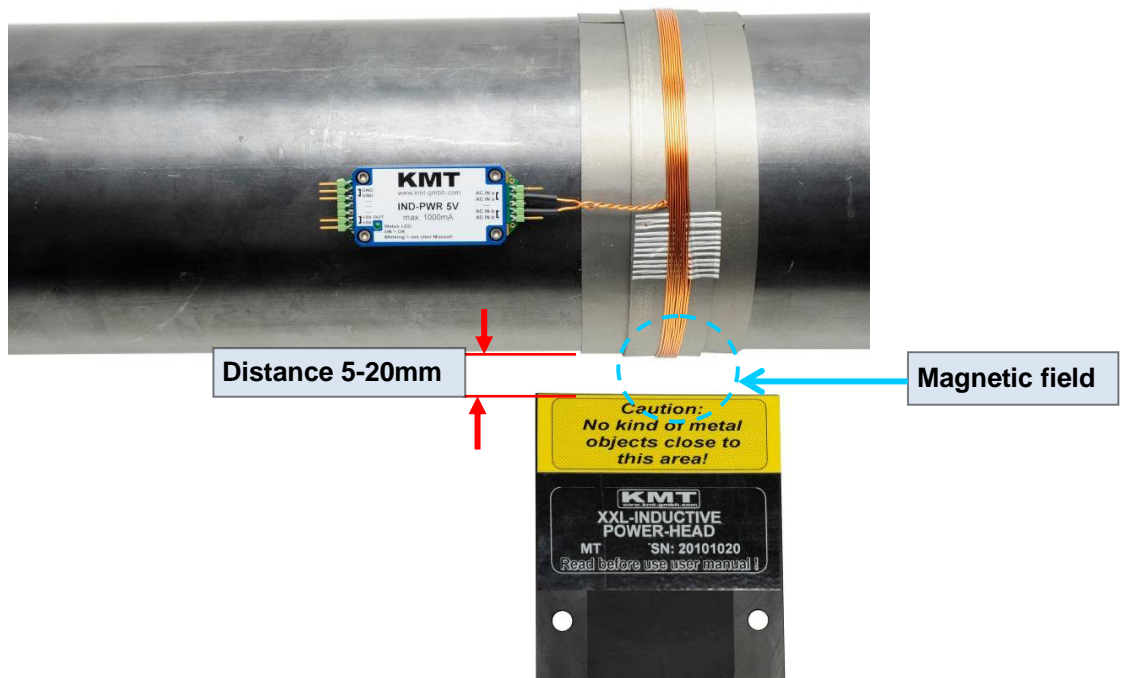

Distance dependent of current consumption e.g.:  
 1000mA at 5-10mm, 500mA at 10-15mm and 250mA at 15-20mm

**IND-PWR-HEAD-XXL**  
for diameters up to 400mm



**IND-PWR-HEAD-XXXL**  
for diameters up to 1000mm



**Caution for use of XXL and XXXL power heads!  
Cable must unrolled for use, otherwise it will warm up!**

# Dimensions of IND-PWR-HEAD-XXL

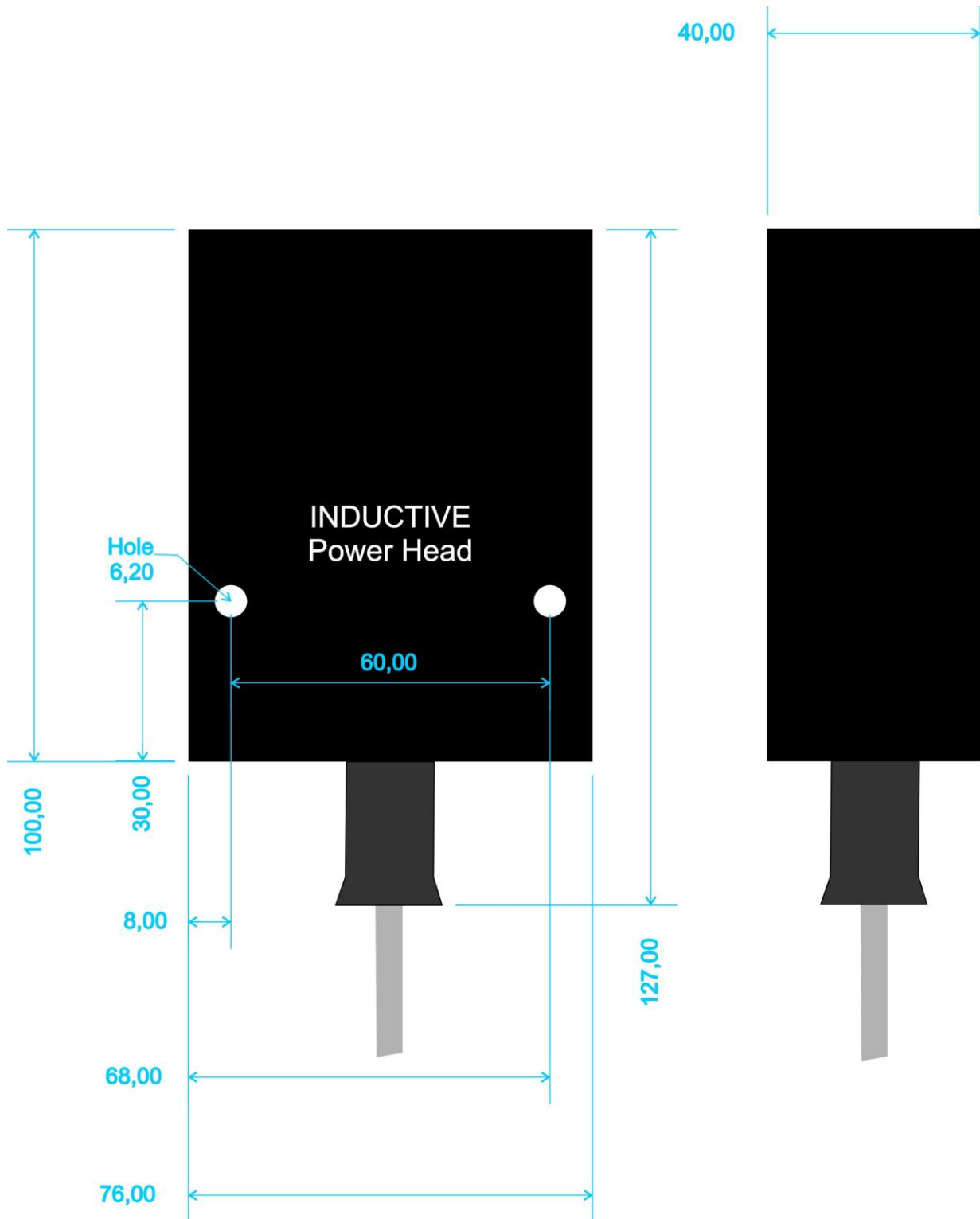

## Dimensions of IND-PWR-HEAD-XXXL

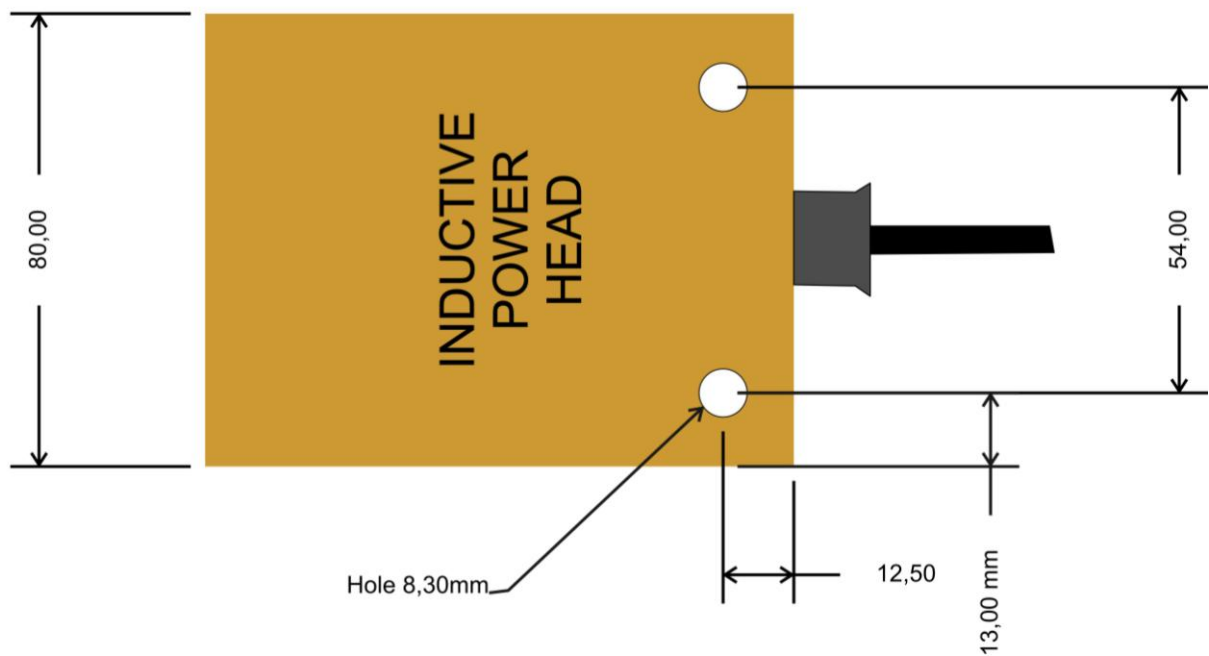
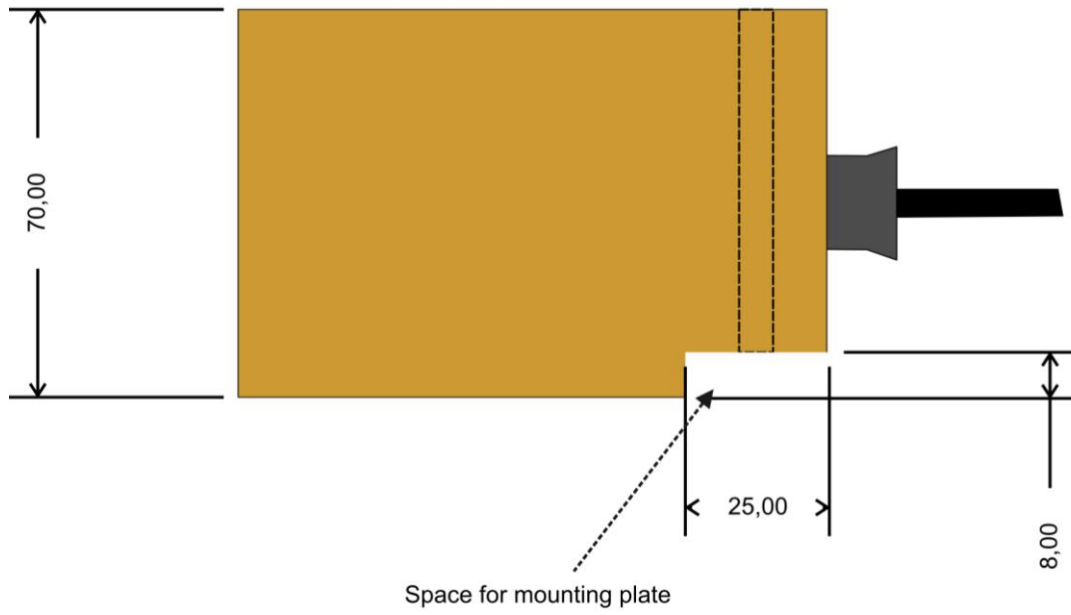

Following must be considered at the mounting of the inductive power head

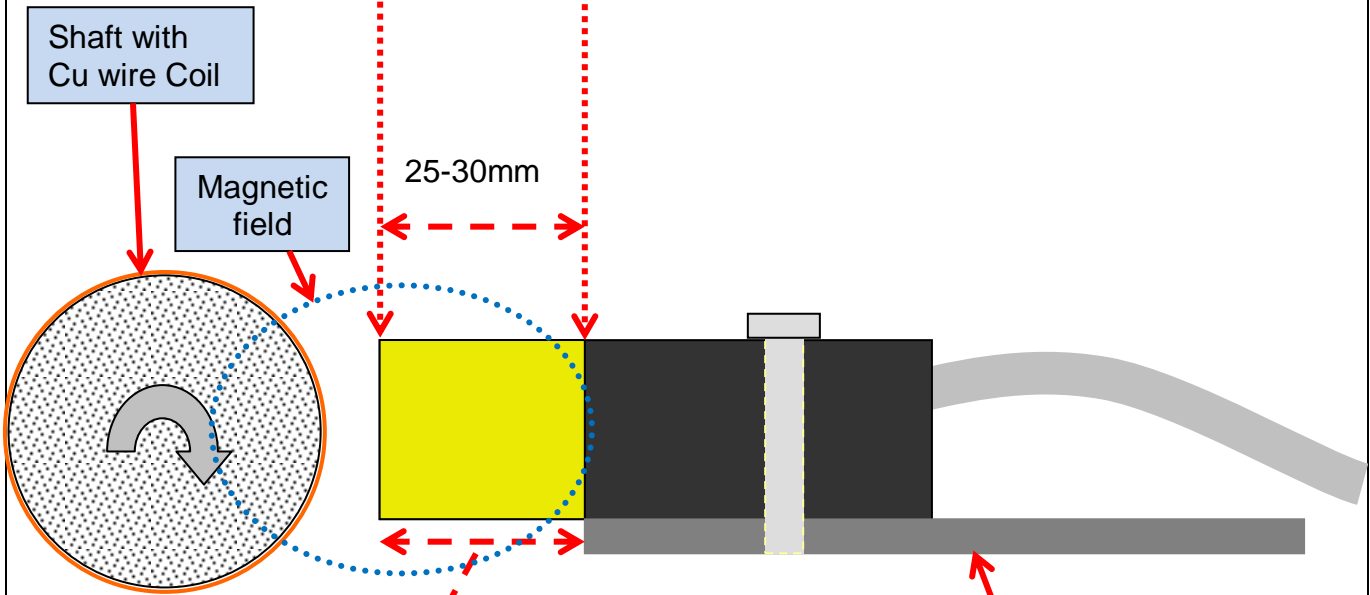

**Don't use for mounting any kind metal in this area (25-30mm)! Otherwise magnetic energy will flow in the metal and decrease the distance between power head and coil (on shaft)!**

Example of mounting

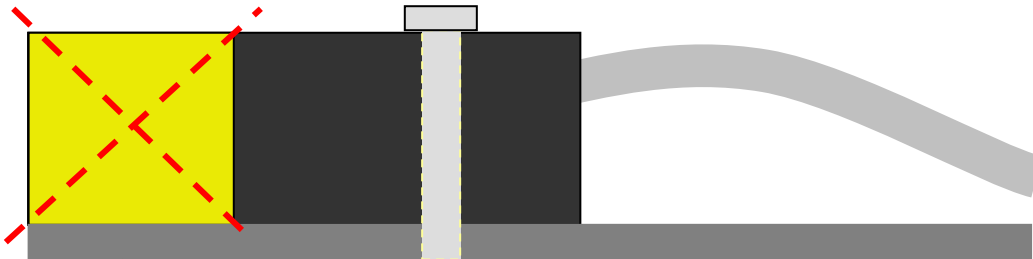

**Wrong!!! Mounting (only if metal) plate cover the active area of**

# MTP-IND-PWR-XXL

## Pin connection

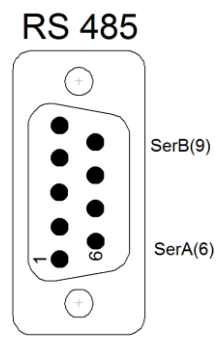

CONTROL - Not used!

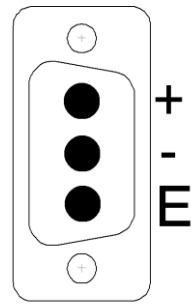

DC 10-30V (120 WATT)

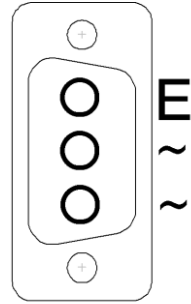

AC 25-35kHz output for power head

E= have no function

## Powering and AC out

**RED STATUS LED:**  
LED flashing = auto adjustment  
LED ON = finish  
IND-resonance of  
Power head reached!

**GREEN power control LED**

**Power Switch**

**Power INPUT  
DC 10...30V  
(>120WATT)**

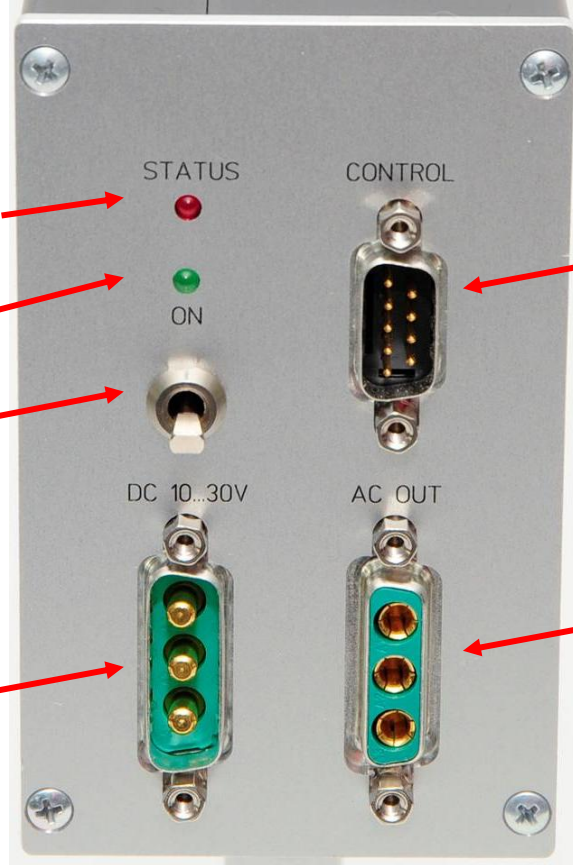

**Control out of function**

**AC 25-35kHz output  
for power head**

## Safety notes for inductive powering

- The device should only be applied by instructed personnel.
- The power head emits strong magnetic radiation at 30-60 kHz to a distance of 20 cm. Therefore persons with cardiac **pacemakers** should **not work** with this device!
- Magnetic data storage media should be kept in a distance of at least 3m from the power head to avoid data loss. The same is valid for electromagnetic sensitive parts, devices and systems.
- Do **not place** the power head in the switched-on state **on metallic objects**, because this results in eddy currents which could overload the device and strongly heat up small objects. Also the probe could be destroyed!
- No metallic objects, other than the disc-type coil, should be located in the air gap of the power head. The same applies to metallic parts within a radius of up to 30 mm in all directions.
- Do not use damaged or faulty cables!
- Never touch in the area between shaft and inductive head, the rotating shaft itself or rotor electronic contacts during operation!
- This is a "Class A" system suitable for operation in a laboratory or industrial environment. The system can cause electromagnetic interferences when used in residential areas or environments. In this case the operator is responsible for establishing protective procedures.