

MT1-PCM

Digital Radio Telemetry System for Strain Gage Applications on Rotating Shafts

“Gain and Auto Zero setting direct from Receiver Side!”



- Easy to assemble and operate
- Strain gage sensors (>350 Ohm)
- Full- and half bridge configuration
- Excitation fixed 4 Volt DC
- Auto-Zero adjustment - Setting receiver side
- Gain: 250-8000 - Setting receiver side
- External shunt calibration
- Digital transmission via radio telemetry 433, 868MHz
- Powering through Lithium battery, >22h work time
- Distance 1-10 meter (rotating application)
- Up to 4 system can work in different radio freq.
- Signal bandwidth 0...500Hz (-3dB)
- Output +/-10V and add. 4-20mA (Option)
- System accuracy <0.2%

General Description

The MT1-PCM single-channel telemetry system offers the easiest handling for the wireless radio transmission of strain gage signals from rotating shafts.

The encoder has dimensions (MT1-PCM-STG) of 62x27x13mm (without connectors) and transmitter (40k-Tx) of 62x27x11mm (without connectors). Each module have a weight of about 30g. The encoder/transmitter parts are simply mounted on the rotating shaft with a special fiber reinforced tape and add steel trip.

Powering of the transmission part is with battery 6-9V, power consumption 70mA. The digital data transfer between transmitter and receiver is realized by radio frequency 433MHz or 868MHz, transmitting power 10mW

Functional Description

The MT1-PCM transmitter transmits a digital radio frequency signal to the receiver. The distance between transmitter and receiver ([depends of application](#)) is 1-10 meter. "Not rotating Point to Point application upto100m at free view"



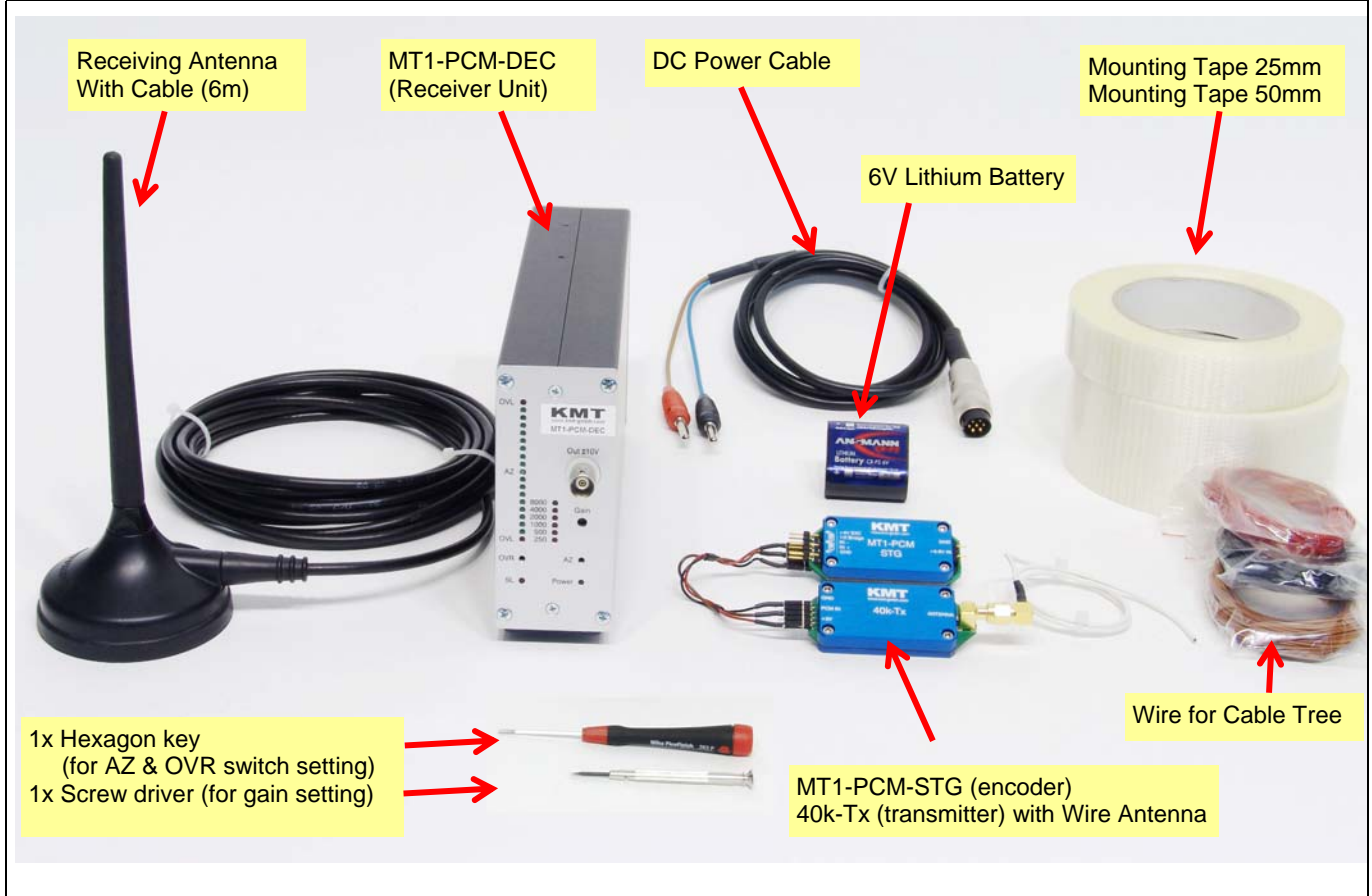

The receiver unit offers a BNC connector at the front panel with analog outputs ± 10 V. An LED bar indicator shows the actual level and a successful Auto Zero calibration. Overload is indicated by the last LED's in pos. or neg. direction of the bar graph. These OVL-LED's operate in peak-hold mode and are reset by pressing the overload switch.

Strain gage sensors (>350 Ohm) in full- and half- bridge configuration can be directly connected to the transmitter. The excitation is fixed to 4 Volt DC and the gain is set by the gain switch on the receiver side. An auto-zero (AZ) adjustment is executed by pressing the AZ button on the front side of the receiver. The successful AZ operation is indicated by a yellow LED in the middle of the LED bar indicator. When the AZ completes the LED continuously illuminates. A continued flashing of the yellow LED indicates some error in the AZ electronics. In this case please contact the support of KMT. Additional to the AZ you have the possibility to calibrate the bridge by external shunt (+ and -). The AZ setting is stored in a Flash-RAM and thus is not lost during power-off. Use only shielded sensor cable.

MT1-PCM Set Contains:



Technical Data - Transmitter for STG

	<p>TEL1-PCM-STG</p> <p>Strainage: Full and 1/2 bridge >350 Ohm, Excitation: 4 VDC (fixed) Gain: 250; 500; 1000; 2000; 4000; 8000 (select able from receiver side) Shunt Cal: Via external resistor for positive and negative calibration Analog bandwidth: 0 - 500 Hz (-3 dB), Scanning rate 2000 Hz Operating temperature: - 10 to + 80 °C Powering: Battery 6-9V</p>
	<p>TEL1-PCM-TH-K</p> <p>Thermo couple type: K Range: 0-1000°C; 0-500°C; 0-250°C; (select able from receiver side) Analog bandwidth: 0 - 10 Hz (-3 dB), Scanning rate 2000 Hz Operating temperature: - 10 to + 80 °C Powering: Battery 6-9V</p>
	<p>TEL1-PCM-VOLT</p> <p>Volt inputs: +/-10V, 5V, 2.5V, 1.25V, 0.625V or 0.3125V Analog bandwidth: 0 - 500 Hz (-3 dB), Scanning rate 2000 Hz Operating temperature: - 10 to + 80 °C Powering: Battery 6-9V</p>
	<p>40k-Tx transmitter:</p> <p>Carrier frequency: 433MHz or 868MHz, 10mW transmitting power Dimensions: MT1-PCM-STG = 62x27x13mm (without connectors) 40k-Tx = 62x27x11mm (without connectors) Weight: each about 30 gram (without cables) Static acceleration: up to 3000g Powering: trough MT1-PCM-STG (VOLT/TH-K), +5V/GND</p>

Technical Data - Receiver

<div style="display: flex; justify-content: space-around;"> <div data-bbox="135 1220 406 1825">  <p style="text-align: center;">Front side</p> </div> <div data-bbox="422 1220 694 1825">  <p style="text-align: center;">Rear side</p> </div> </div>	<p>TEL1-PCM-DEC</p> <p><u>Font side:</u></p> <p>Analogue output: +/-10V via BNC Gain setting : via screw switch Auto Zero setting: via micro switch Overload LED's (Red ON) reset: via micro switch Autozero LED: Yellow ON- successful AZ (output signal <+/-30mV) Yellow OFF- not successful AZ (output sign. >+/-30mV) <i>if flashing, call support of KMT, error in EPROM</i> Green LED's: Bargraph +/- SL LED: Red ON = if error of data transmitting SL LED: Red Flashing = if the battery is empty Power ON LED: Red ON = if power switch on</p> <p><u>Rear side:</u></p> <p>Antenna: Input for receiving antenna RF Level: LED indicator for radio frequency Fuse LED: Flashing if fuse is defect Powering: 10-30V DC, Input via 7pol. Tichel Switch: ON/OFF Operating temperature: - 10 to + 70 °C Dimensions: 200 x 105 x 44 (without connectors!) Weight: 950 grams Static acceleration: up to 200g System accuracy (without sensor): +/- 0.2 %</p>
---	---

Block Diagram:

Transmitting Wire Antenna

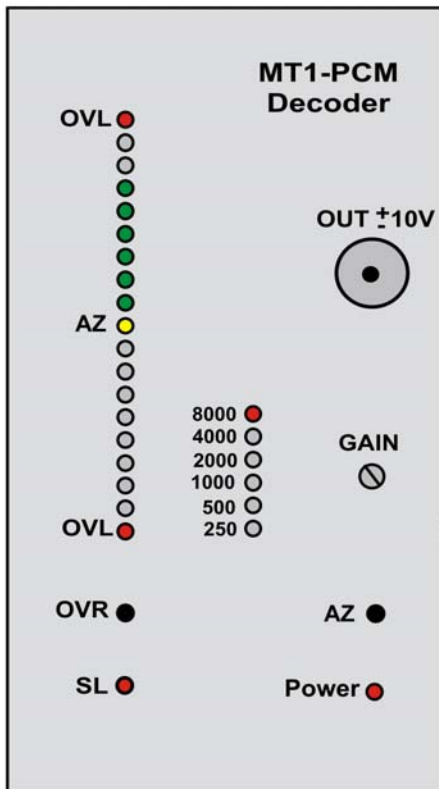
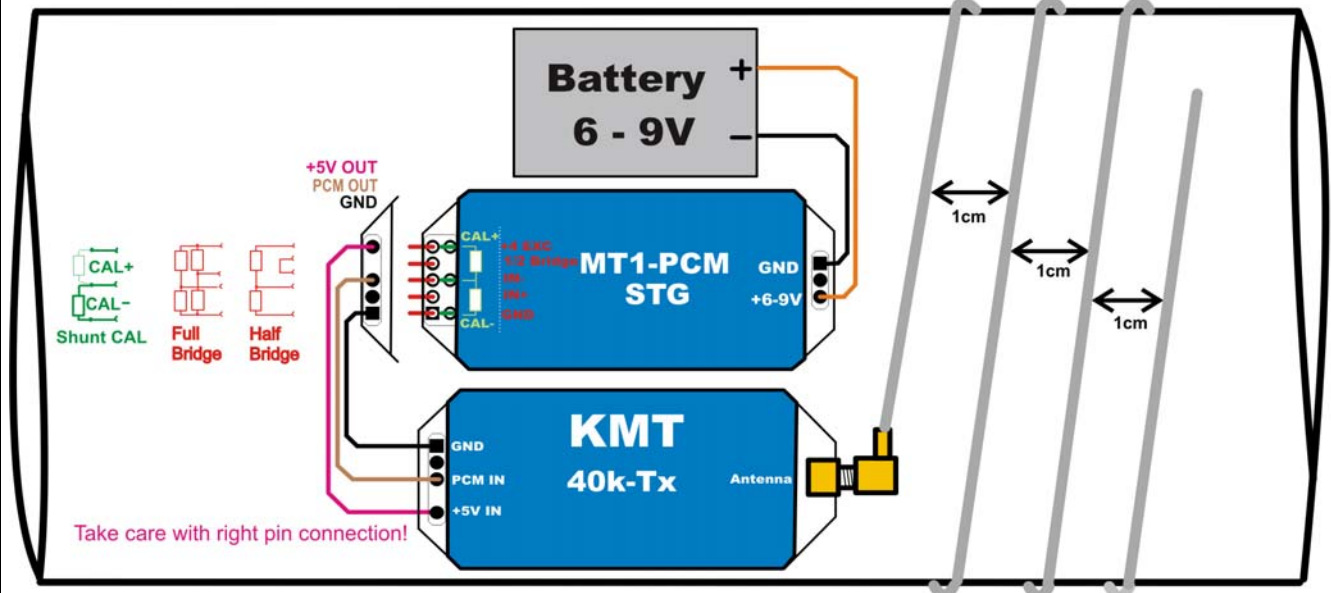

Distance 1-10m, depend of application!

